

Easyfit multisensor for IoT

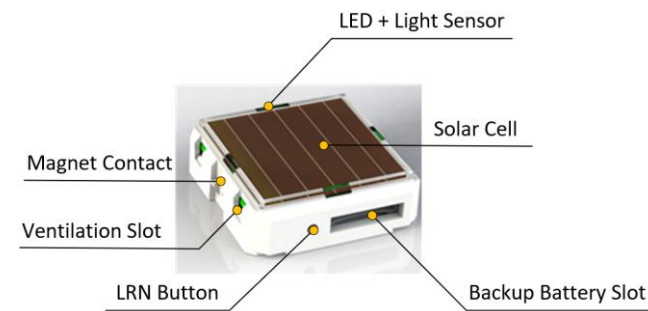

Package Contents

- STM 550x sensor
- Wall mount plate
- Face plate
- Adhesive tape
- Magnet

Tools Required

- Screwdriver
- Backup battery (CR 1632) if needed

Product Description

EMSIx Easyfit multisensor for IoT applications is a self-powered device that monitors environmental parameters such as temperature, humidity, illumination, acceleration and magnet contact status.

EMSIx reports the measured parameters wirelessly using EnOcean radio messages using EnOcean Alliance Equipment Profiles (EEP).

EMSIx operates self-powered in most applications based on available light in the environment. It can be flexibly mounted on any surface without the need for any wiring.

Key parameters of EMSix such as the reporting interval and the measured parameters can be configured using the integrated NFC interface.

Additionally, a simple user interface consisting of one button and one LED allows for fast configuration without additional tools.

Functional Description

EMSIx reports regularly with a transmission interval of approximately 60 seconds (default) the status of the measured parameters.

If vibration is detected for the first time by the permanently active acceleration sensor or if the status of the magnet contact (open or closed) changes then a radio telegram will be transmitted immediately.

Product Features

- Measures a large variety of environmental parameters via integrated sensors
- Sends wireless messages to other devices at regular intervals reporting the sensor status
- Harvests ambient solar energy to power the sensors and enable wireless communication
- Provides option for supplemental battery for extreme low-light conditions
- Can be configured via simple user interface or via NFC
- Can be mounted easily on most materials using adhesive tape (included) or screws (not included)

Specifications (typical values at 25°C)

Integrated sensors	Temperature (-20 °C ... 65 °C) ⁽¹⁾ (-4 °F ... 150 °F) ⁽¹⁾ Humidity (0 % ... 100 % r.h.) ⁽¹⁾ Illumination (0 ... 10.000 lx) Acceleration (-2g ... 2g each axis) Magnet contact (Open, Closed)
Radio standard	EnOcean
Supported EEP (selectable via NFC)	D2-14-41 (default) A5-02-05, A5-04-03, A5-06-03 A5-06-02, A5-14-05, D5-00-01
Transmission Interval	Approximately every 60 seconds Configurable via NFC between 3 s and 65535 s
Radio range	100 m (325 ft.) direct line of sight 30 m (100 ft.) indoor environment
Power supply	Integrated solar cell Option for backup battery (CR1632)
Minimum light level	200 lux for 8 hours per day ⁽²⁾
Time to first transmission after empty energy store	5 minutes at 200 lux ⁽²⁾
Operating time in darkness with full energy store	96 hours
Local User Interface	1 Button, 1 LED
Dimensions	49 mm L x 49 mm W x 13,3 mm H (1.93" L x 1.93" W x 0.52" H)
Operating conditions	Indoor use only -5 °C to 25 °C (32 °F to 115 °F) 20 % to 85 % r.h. (non-condensing)
Agency Compliance	CE, FCC, IC

(1) EMSix is designed for indoor use only according to the operating conditions specified above.

(2) For lux reference, OSHA standards require a minimum of 323 lux for office areas. Divide by 10 for a rough translation from lux to footcandles.

1. Planning

Remove the sensor from its packaging and place it under a bright light for 5 minutes to provide the required startup charge.

In the meantime, take a moment to plan for the sensor's successful operation and optimal communication with other system components.

The installation location should be selected according to the following criteria:

- Measurement accuracy
- Communication distance
- Available light

To achieve best possible measurement accuracy, it is essential to mount the sensor at a location that is representative for the use case (e.g. mount a temperature sensor at desk height, not at ceiling height) and where external influence (e.g. airflow from HVAC systems or direct sun exposure) is minimized.

For light sensor applications, ensure that the light sensor is orientated directly towards the measurement target area.

For magnet contact sensor applications (e.g. door or window monitoring), the distance between magnet and the magnet contact within the sensor should be less than 1 cm (0.4").

To ensure reliable communication, minimize the communication distance to the receiver and avoid radio transmission obstacles (especially large metallic items) as much as possible.

To enable self-powered operation, choose a location that provides consistent and adequate light for the supply of EMSix via its solar cell (200 lux for 8 hours per day for fully self-supplied operation, this can be electric or natural light).

2. Installing

Read and understand all instructions completely before starting the installation.

1. Select the installation location as described above and decide if the sensor will be screwed or glued onto the chosen installation location
2. If a backup battery is required, then insert it into the module according to the orientation shown on housing
3. Press the button one time to exit "storage mode" and start sensing and transmitting.

4. Commission (learn in) the sensor into the receiver according to the instructions of the receiver manufacturer
5. Position the sensor at the selected location, press the LRN button and verify that the telegram can be received reliably (sufficient signal strength) by the receiver.
6. Magnet sensor: Determine where the magnet contact is located within EMSix based on the illustration below (the location of the magnet contact is shown in green). The triangle (marked in red) at the bottom of the module points towards the side where the magnet has to be installed.

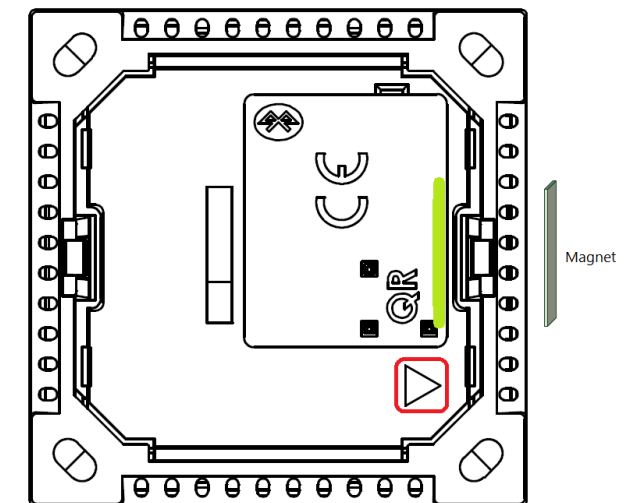

Attach the magnet to the intended surface (e.g. door or window) so that it aligns with the center of this side and verify that the distance between magnet and sensor housing is less than 1 cm (0.4"). Verify that the state (e.g. door open or closed) is reported as expected.

7. If extensive functional testing is required, then install a CR1632 backup battery into the backup battery holder and quickly press the LRN button twice to start functional test mode. In this mode, the sensor will transmit telegrams every 3 seconds for 2 minutes.
8. Screw mounting: use the wall mount to mark the location of the drill holes at the chosen installation location. Select suitable screws and wall-plugs and install the wall mount. Do not over-tighten the screws.

9. Install the sensor module onto the wall mount plate as shown below.

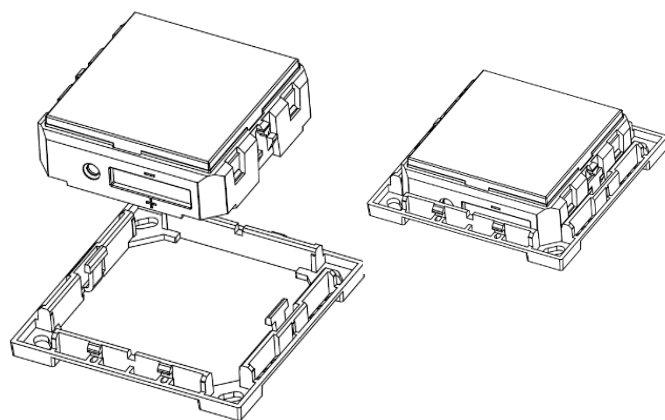

Note that backup battery and LRN button are protected from access after module installation into wall mount.

10. Adhesive mounting: Attach adhesive tape to the backside of the sensor module and then firmly press sensor and wall mount plate onto the surface. Verify proper attachment to the surface before proceeding.

11. Snap the face plate onto sensor module and wall mount as shown below. Note that face plate and wall mount plate are keyed with a notch to ensure proper alignment.

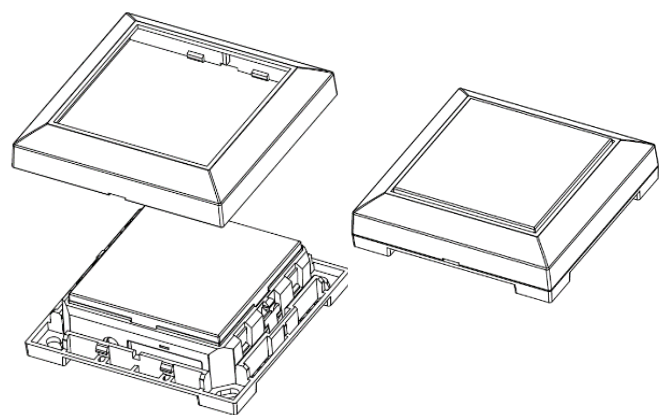

12. Should disassembly be required at a later point, insert a small flat screwdriver into the slot of the face plate (marked in green below) and push it upwards to remove it from the wall mount plate.

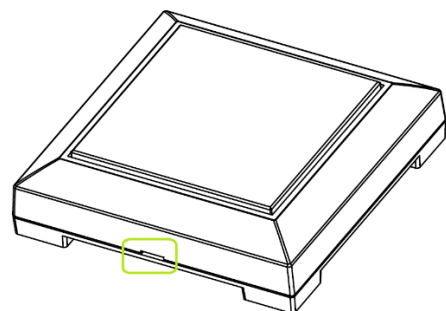

After that, remove the sensor and the wall mount from the wall, insert the screwdriver from the back side between the module and the snap hook of the wall mount and push out the module towards the front.

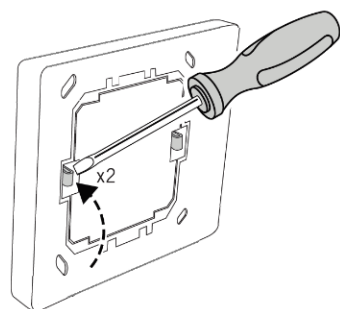

If necessary, the module can also be extracted from the front side without removing the wall mount from its installation location. To do so, carefully insert the screwdriver from the front between snap hook and module, press the hook outwards and lift out the module.

13. Perform a function test to determine correct operation after installation as described below. Verify that the telegrams from EMSIx are correctly received and that the reported sensor values are in line with expectation.

3. Device Configuration

EMSIx contains a Learn (LRN) button that can be used for the following simple configuration tasks:

- Wake-up and LRN telegram transmission**
EMSIx will be delivered in low power mode with the radio disabled. To start-up EMSIx, press the LRN button once. EMSIx will transition to normal operation mode, blink the LED and transmit a commissioning telegram identifying its parameters.
- Storage mode**
Pressing the LRN button between 3 and 5 seconds will put EMSIx into storage mode intended for periods of storage or transport. In this mode, radio transmissions are disabled and as much as possible is conserved. To exit storage mode, see above.
- Function Test**
Short pressing the LRN button 2 times within less than 1 second will start function test mode. In this mode, EMSIx will measure and report at a high rate for a period of 2 minutes. The LED will flash whenever a measurement and report takes place. Any subsequent press will stop the function test.

- Enable / disable LED**
Short pressing the LRN button 3 times within less than 2 seconds will toggle the indication LED between enabled and disabled.
- Factory reset**
Pressing and holding the LRN button for at least 8 seconds will reset EMSIx to its default settings

More complex setup and configuration tasks can be executed using the NFC interface with a suitable NFC reader. Check the user manual for a detailed description.

4. Trouble Shooting

Use below table for common problems. Otherwise, consult the EMSIx user manual for detailed explanation about EMSIx functionality.

Problem	Solution Checklist
Sensor not operating	<ul style="list-style-type: none"> Press LRN button to wake-up the device and transmit a teach-in message, verify the LED blinks. If no blink is observed, then provide an initial charge by placing EMSIx under bright light for at least 5 minutes. Use a factory reset to reset EMSIx to its default configuration.
Unexpected sensor readings	<ul style="list-style-type: none"> Review installation instructions in this document and in the user manual Magnet contact: Ensure that the distance between magnet and sensor is less than 0.5"
Sensor messages not received	<ul style="list-style-type: none"> Verify that a wireless message is sent (LED blinks whenever a message is sent) Check for environment or range issues (e.g. obstruction with large or metallic objects) Verify that the receiver supports the selected EEP; change the EEP if necessary Verify that the receiver is properly configured to accept messages from EMSIx

5. Additional information

Scan the QR code below to access the EnOcean website:



6. Agency certifications



Hereby, EnOcean GmbH, declares that this radio equipment is in compliance with the essential requirements and other relevant provisions of Directive 2014/53/EU. A copy of the Declaration of Conformity can be obtained from the product webpage at www.easyfit-controls.com



WEEE Directive Statement of the European Union

This marking indicates that this product should not be disposed with other household wastes throughout the EU. To prevent possible harm to the environment or human health from uncontrolled waste disposal, recycle it responsibly to promote the sustainable reuse of material resources.
Germany: WEEE-Reg-No.: DE 93770561
UBA Reg-No.: 21008516

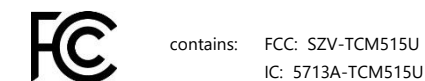

This device complies with part 15 of the FCC rules and Industry Canada ICES-003. Operation is subject to the following two conditions: (1) This device may not cause harmful interference, and (2) this device must accept any interference received, including interference that may cause undesired operation.

IMPORTANT! Any changes or modifications not expressly approved by the party responsible for compliance could void the user's authority to operate this equipment.

Le présent appareil est conforme aux CNR d'Industrie Canada applicables aux appareils radio exempts de licence. L'exploitation est autorisée aux deux conditions suivantes: (1) l'appareil ne doit pas produire de brouillage, et (2) l'utilisateur de l'appareil doit accepter tout brouillage radioélectrique subi, même si le brouillage est susceptible d'en compromettre le fonctionnement.