

www.easyfit-controls.com

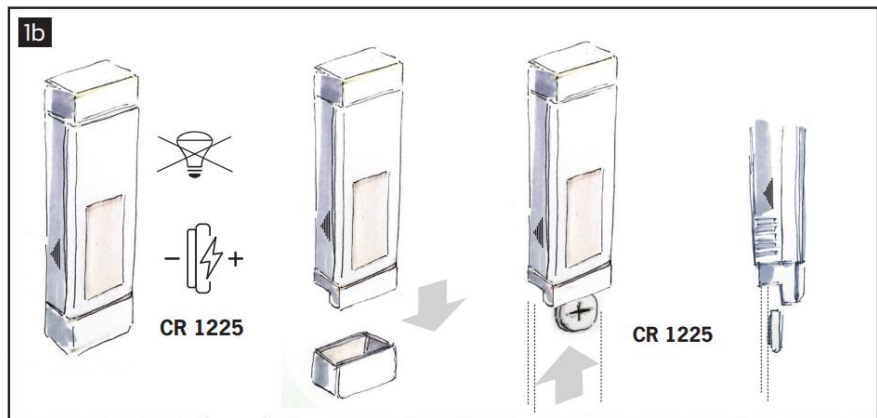

2

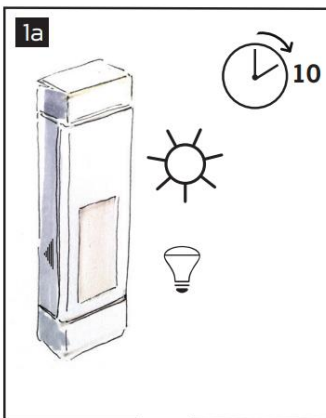
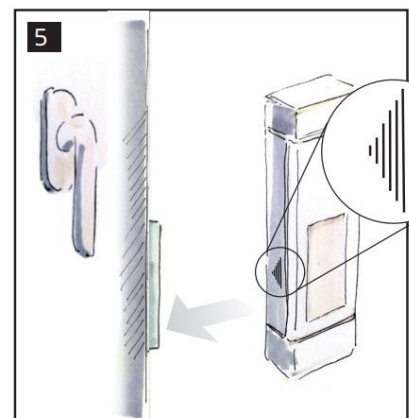
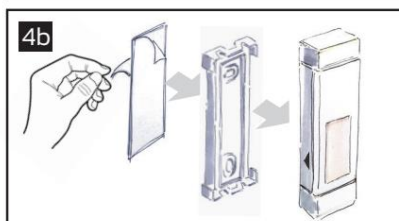
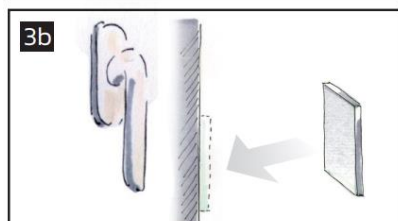
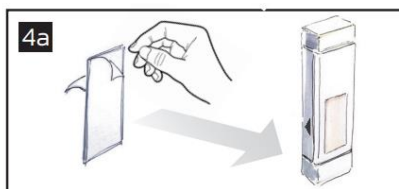
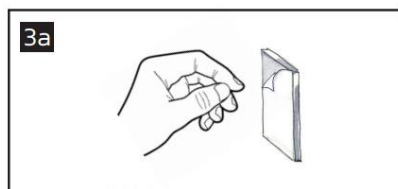
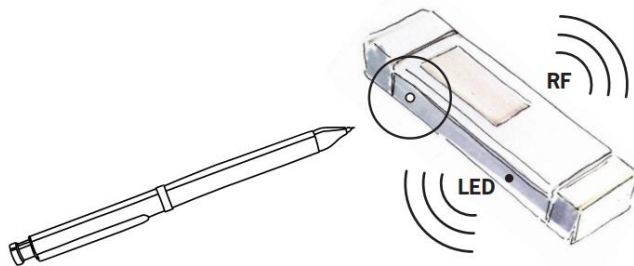

<p>EN</p> <p>Intended use:</p> <ul style="list-style-type: none"> This product is intended for indoor usage in closed dry rooms, for details see user manual. The product must not be used in any relation with equipment that supports, directly or indirectly, human/animal health or life or with applications that can result in danger for people, animals or real value. The product is not suitable for use in mechanically or environmentally challenging environments including (but not limited to) environments with heavy vibrations, mechanical shocks, very high humidity, very dusty or in explosive atmosphere. The installation and assembly of electrical equipment may only be performed by a skilled electrician. <p>Basic safety instructions:</p> <ul style="list-style-type: none"> Risk of suffocation! Do not leave the packaging material lying around. Children could swallow the small parts and choke on them. Install and operate product according to user manual and do not modify product. The product should not be exposed to rapid temperature changes shortly before or during operation; condensation of moisture has to be avoided. Wrong cleaning may damage the product; we suggest cleaning with soft and damp tissue. <p>Disposal:</p> <ul style="list-style-type: none"> Product: Dispose of the used components at an official collection point for electronic waste or at your local dealer. Packing: Please use the recycling operators known to you. <p>Germany: WEEE-Reg.-No.: DE 9377056</p>	<p>DE</p> <p>Verwendungszweck:</p> <ul style="list-style-type: none"> Dieses Produkt ist für den Innenbereich in geschlossenen, trockenen Räumen vorgesehen. Details siehe Bedienungsanleitung. Das Produkt darf nicht in Verbindung mit Geräten verwendet werden, die direkt oder indirekt menschlichen Gesundheits- oder Lebenssichernden Zwecken dienen oder durch deren Betrieb Gefahren für Menschen, Tiere oder Sachwerte entstehen können. Das Produkt eignet sich nicht für den Einsatz in mechanisch oder umweltbedingt kritischen Umgebungen, einschließlich (aber nicht beschränkt auf) Umgebungen mit starken Vibrationen oder mechanischen Stößen, hoher Luftfeuchtigkeit, viel Staub oder in explosiver Atmosphäre. Installation und Montage von elektrischen Geräten darf nur von einem Elektrofachmann durchgeführt werden. <p>Grundlegende Sicherheitshinweise:</p> <ul style="list-style-type: none"> Erstklassungsgefahr! Lassen Sie Verpackungsmaterial nicht herumliegen. Kinder könnten die Teile verschlucken und daran ersticken. Installieren und betreiben Sie das Produkt gemäß Bedienungsanleitung. Ändern Sie das Produkt nicht. Das Produkt sollte kurz vor oder während des Betriebs keinen schnellen Temperaturänderungen ausgesetzt werden. Kondensation von Feuchtigkeit muss vermieden werden. Falsche Reinigung kann das Produkt beschädigen; Wir empfehlen ein weiches, feuchtes Tuch. <p>Entsorgung:</p> <ul style="list-style-type: none"> Produkt: Entsorgen Sie die Komponenten bei einer offiziellen Sammelstelle für Elektronik- Abfälle oder bei Ihrem örtlichen Händler. Verpackung: Bitte entsorgen Sie diese bei den Ihnen bekannten Recycling-Betreibern. WEEE-Reg.-Nr. : DE 93770561 	<p>FR</p> <p>Utilisation prévue:</p> <ul style="list-style-type: none"> Ce produit est destiné à une utilisation en intérieur, dans des locaux secs et fermés. Pour plus de détails, se référer au manuel d'utilisateur. Le produit ne doit pas être utilisé avec un équipement qui concerne, directement ou indirectement, la santé humaine ou animale, la vie, ou avec des applications pouvant entraîner un danger pour les personnes, les animaux ou de valeur réelle. Le produit n'est pas adapté pour une utilisation dans des contextes environnementaux ou mécaniques difficiles comprenant, (liste non exhaustive) des environnements à fortes vibrations, avec chocs mécaniques, avec une humidité excessive, une atmosphère poussiéreuse ou explosive. L'installation et l'assemblage d'équipements électriques ne peuvent être effectués que par un électricien qualifié. <p>Instructions de sécurité de base:</p> <ul style="list-style-type: none"> Risque d'asphyxie ! Ne laissez pas les matériaux d'emballage à l'intérieur. Les enfants pourraient avaler les petites pièces et risquer de s'étouffer. Installez et utilisez le produit selon le mode d'emploi. Ne modifiez en aucun cas le produit. Le produit ne doit pas être exposé à de brusques changements de température (avant ou pendant le fonctionnement). Condensation et humidité doivent être évitées. Un nettoyage incorrect peut endommager le produit. Nous suggérons de le nettoyer avec des tissus doux et humides. <p>Disposition:</p> <ul style="list-style-type: none"> Produit: Jeter les composants utilisés dans un point de collecte pour déchets électroniques ou chez votre revendeur local. Emballage: utilisez le circuit de recyclage habituel. 	<p>NL</p> <p>Beoogd gebruik:</p> <ul style="list-style-type: none"> Dit product is bedoeld voor gebruik binnen in afgesloten droge ruimtes. Zie voor details de gebruiksaanwijzing. Dit product mag niet worden gebruikt in combinatie met apparatuur die, direct of indirect, menselijke/dierlijke gezondheid of leven ondersteunt met toepassingen die gevaar kunnen opleveren voor mensen, dieren of zaken. Het product is niet geschikt voor gebruik in mechanische of qua omgeving uitdagende condities, met inbegrip van (maar niet beperkt tot) omgevingen met sterke trillingen, mechanische schokken, zeer hoge vochtigheid, hoog stofgehalte of een explosieve atmosfeer. De installatie en montage van elektrische apparatuur mag alleen worden uitgevoerd door een deskundige electricien. <p>Basisveiligheidsinstructies:</p> <ul style="list-style-type: none"> Risico op verstikking! Laat het verpakkingsmateriaal niet rondslingeren. Kinderen kunnen de kleine onderdelen inslikken en stikken. Installeer en gebruik het product in overeenstemming met de gebruiksaanwijzing en modificeer het product niet. Het product mag vlak voor of tijdens gebruik niet worden blootgesteld aan snelle temperatuurwijzigingen. Condensatie of vochtigheid moet worden vermeden. Verkeerde reiniging kan het product beschadigen. Wij adviseren reiniging met een zachte vochtige tissue. <p>Verwijdering:</p> <ul style="list-style-type: none"> Product: verwijder de gebruikte componenten bij een officieel inzamelingsstation voor elektronisch afval of bij uw lokale leverancier. Verpakking: gebruik de bij u bekende recyclinginstanties. 	<p>IT</p> <p>Uso previsto:</p> <ul style="list-style-type: none"> Questo prodotto è destinato per l'uso all'interno nei ambienti chiusi e asciutti. Per dettagli vedere il manuale dell'utente. Il prodotto non deve essere utilizzato in alcun modo con apparecchiature che supportino direttamente o indirettamente la salute umana o con applicazioni che possono provocare pericoli o danni per persone, animali o valori reali. Il prodotto non è adatto per l'uso nei ambienti con difficoltà meccaniche o ambientali, compresi (ma non limitati) nei ambienti con vibrazioni pesanti, urti meccanici, umidità elevata, molto polverosi o in un'atmosfera esplosiva. L'installazione e l'assemblaggio di apparecchiature elettriche possono essere eseguite solo da un esperto elettricista. <p>Istruzioni di base di sicurezza:</p> <ul style="list-style-type: none"> Rischio di soffocamento! Non lasciare il materiale d'imballaggio in giro. I bambini potrebbero inghiottire le piccole parti con rischio di soffocamento. Installare e utilizzare il prodotto in base al manuale dell'utente e non modificare il prodotto. Il prodotto non deve essere esposto a rapidi cambiamenti di temperatura poco prima o durante l'operazione; la condensazione dell'umidità deve essere evitata. La pulizia errata può danneggiare il prodotto; Si consiglia di pulire con un tessuto morbido e umido. <p>Disposizione:</p> <ul style="list-style-type: none"> Prodotto: Smaltire i componenti utilizzati in un punto di raccolta ufficiale per rifiuti elettronici o presso il rivenditore locale. Imballaggio: Utilizzate gli operatori di riciclaggio conosciuti. 		
<p>Technical Data (EN)</p> <p>Radio module used Technical details Radio protocol</p> <p>Radio frequency Transmission power Radio range, indoor typ. Radio approvals (countries) Energy source Operating temperature Relative humidity</p>	<p>Technische Daten (DE)</p> <p>Funkmodul verwendet Technische Details Radio-Protokoll</p> <p>Radiofrequenz Übertragungsleistung Funkreichweite, Indoor typ. Funkzulassungen (Region) Energiequelle Betriebstemperatur Relative Luftfeuchtigkeit</p>	<p>Données techniques (FR)</p> <p>Module radio utilisé Détails techniques Protocole radio</p> <p>Fréquence radio Transmission Power Gamme radio, type intérieur Autorisations radio (pays) Source d'énergie Température de fonctionnement Humidité relative</p>	<p>Technische gegevens (NL)</p> <p>Radiomodule gebruikt Technische details Radioprotocol</p> <p>Radiofrequentie Zendvermogen Radiobereik, type binn Radiogoedkeuringen (landen) Energiebron Bedrijfstemperatuur Relatieve vochtigheid</p>	<p>Dettagli tecnici (IT)</p> <p>Modulo radio utilizzato Dettagli tecnici Protocollo radio</p> <p>Frequenza radio Potenza di trasmissione Portata segnale tipica (interno) Approvazioni radio (regioni) Fonte d'energia Temperatura di esercizio Umidità relativa</p>	<p>EMCSA</p> <p>STM 320 www.enocean.com EnOcean Radio, EEP D5-00-01 Signal 0x0E, opt. Encryption 868.300 MHz 6.4 dBm 30 m CE (EU) / UKCA (UK) Solar cell, optional CR 1225 -25°C - +65°C 0% - 65%, dry room only</p>	<p>EMCSU</p> <p>STM 320U www.enocean.com EnOcean Radio, EEP D5-00-01 Signal 0x0E, opt. Encryption 902.875 MHz 99 dBuV/m 30 m FCC (US), ISED (CA) Solar cell, optional CR1225 -25°C - +65°C % - 65%, dry room only</p>